

YUKON N Series

Half-Cell N-Type TOPCon
Bifacial Module

465-480W
Module Power Output

22.17%
Max Efficiency

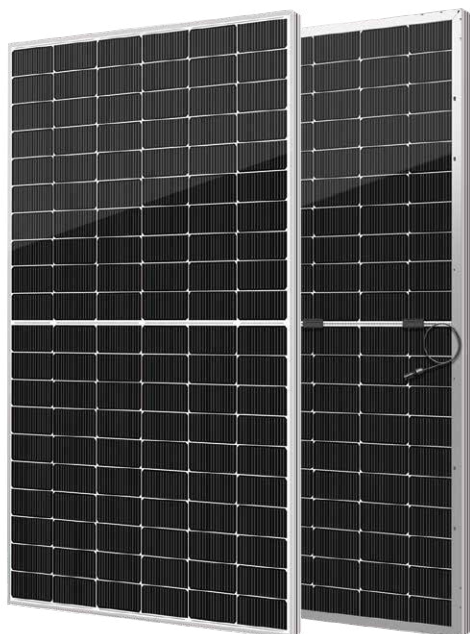

Key Features



High module conversion efficiency



Better temperature coefficient



Super multi busbar technology



Low attenuation long warranty



Superior load capacity



Higher bifaciality



USA based liability insurance



Houston, Texas based company

Warranty

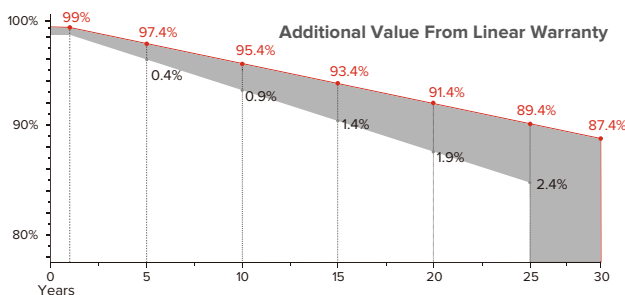

15 <Years> Guarantee on product material and workmanship

30 <Years> Linear power output warranty

Product Certification

IEC61215:2016; IEC 61730:2016; UL1703; UL61730/ETL/CEC

IEC62804 PID

IEC61701 Salt Mist

IEC62716 Ammonia Resistance

IEC60068 Dust and Sand

IEC61215 Hailstone

Fire Type (UL61730):Type29

ISO14001:2015; ISO9001:2015; ISO45001:2018



About SEG Solar

SEG Solar is a leading manufacturer of high-performance solar panels for residential, commercial, and utility applications. The company, headquartered in Houston, Texas, is committed to providing cost-effective and reliable solar solutions that help customers reduce their energy costs and carbon footprint.



Download Datasheet

Electrical Characteristics

| Module Type | SEG-465-BTB-BG | | | SEG-470-BTB-BG | | | SEG-475-BTB-BG | | | SEG-480-BTB-BG | | |
|-------------------------------|----------------|------------|----------|----------------|------------|----------|----------------|------------|----------|----------------|------------|----------|
| | Front STC | Front NOCT | Back STC | Front STC | Front NOCT | Back STC | Front STC | Front NOCT | Back STC | Front STC | Front NOCT | Back STC |
| Maximum Power -Pmp(W) | 465 | 349 | 372 | 470 | 353 | 376 | 475 | 357 | 380 | 480 | 361 | 384 |
| Open Circuit Voltage -Voc(V) | 42.60 | 40.47 | 42.58 | 42.80 | 40.66 | 42.78 | 43.00 | 40.85 | 42.98 | 43.20 | 41.04 | 43.18 |
| Short Circuit Current -Isc(A) | 13.82 | 11.06 | 11.06 | 13.88 | 11.10 | 11.10 | 13.94 | 11.15 | 11.15 | 14.00 | 11.20 | 11.20 |
| Maximum Power Voltage -Vmp(V) | 35.40 | 33.20 | 35.42 | 35.60 | 30.40 | 35.60 | 35.80 | 33.63 | 35.82 | 36.00 | 33.83 | 36.02 |
| Maximum Power Current -Imp(A) | 13.14 | 10.51 | 10.51 | 13.21 | 10.57 | 10.57 | 13.27 | 10.62 | 10.61 | 13.34 | 10.67 | 10.67 |
| Module Efficiency STC-ηm(%) | 21.48 | | | 21.71 | | | 21.94 | | | 22.17 | | |
| Power Tolerance(W) | (0, +3%) | | | | | | | | | | | |
| Maximum System Voltage | 1500V DC | | | | | | | | | | | |
| Maximum Series Fuse Rating | 25 A | | | | | | | | | | | |

 STC: Irradiance 1000 W/m² module temperature 25°C AM=1.5

 NOCT: Irradiance 800W/m² ambient temperature 20°C module temperature 45°C wind speed: 1m/s

Power measurement tolerance: +/-3%

Mechanical Specifications

| | |
|------------------------|---|
| External Dimension | 1909 x 1134 x 30 mm |
| Weight | 27.3 kg |
| Solar Cells | N-TOPCon 182 x 91mm(120 pcs) |
| Front /Back Glass | 2.0mm AR coating semi-tempered glass / low iron |
| Frame | Anodized aluminium alloy |
| Junction Box | IP68 / 3 diodes |
| Connector Type | MC4 |
| Cable Type / Length | 12 AWG PV Wire (UL) /1200 mm |
| Mechanical Load(Front) | 5400 Pa / 113 psf* |
| Mechanical Load(Rear) | 2400 Pa / 50 psf* |

*Refer to SEG installation Manual for details

Packing Configuration

| | | |
|-----------------------|-------|-------|
| Container | 20'GP | 40'HQ |
| Pieces per Pallet | 36 | 36 |
| Pallets per Container | 5 | 24 |
| Pieces per Container | 180 | 864 |

Temperature Characteristics

| | |
|---|-------------|
| Pax Temperature Coefficient | -0.30 %/°C |
| Voc Temperature Coefficient | -0.25 %/°C |
| Isc Temperature Coefficient | +0.046 %/°C |
| Operating Temperature | -40~+85 °C |
| Nominal Operating Cell Temperature (NOCT) | 45±2 °C |

Technical Drawing

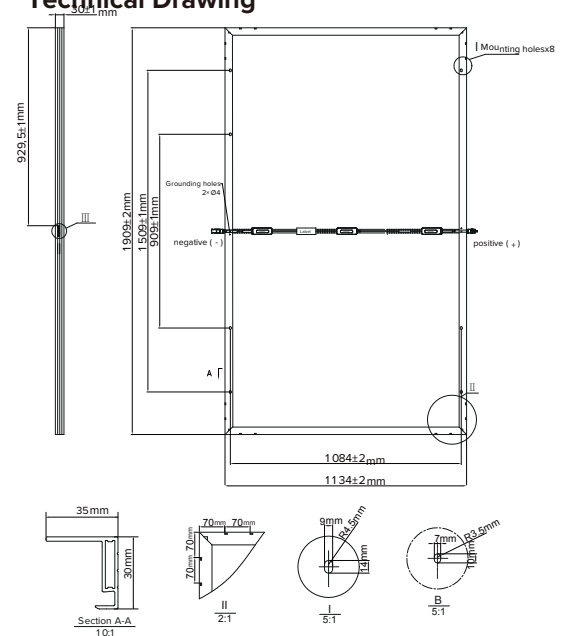

*Refer to SEG installation Manual for details

I-V Curve

